

Front View

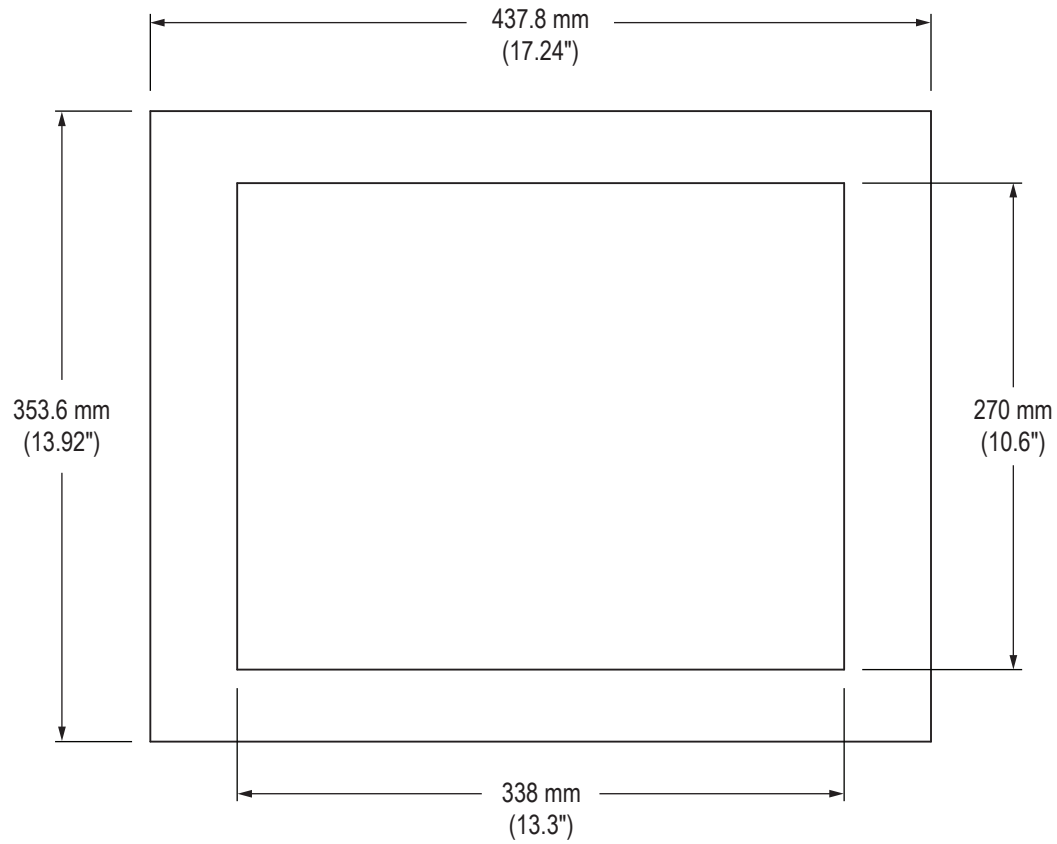

Side View

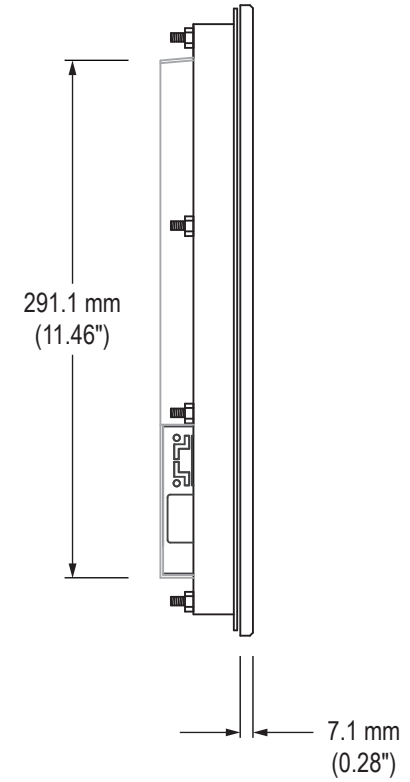

### Rear View (showing Cutout Dimensions)

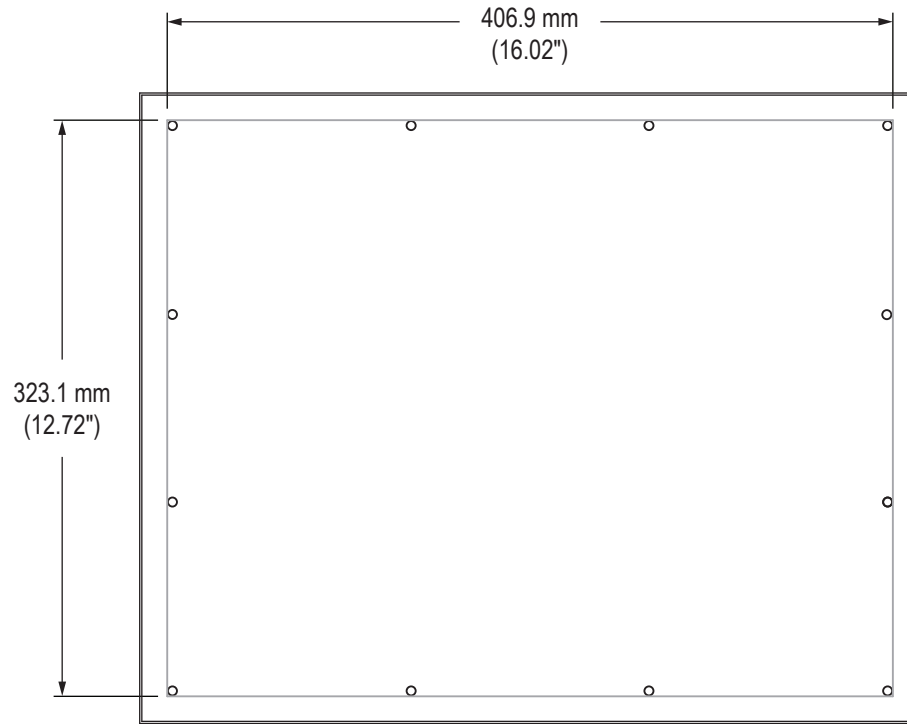

### Bottom View

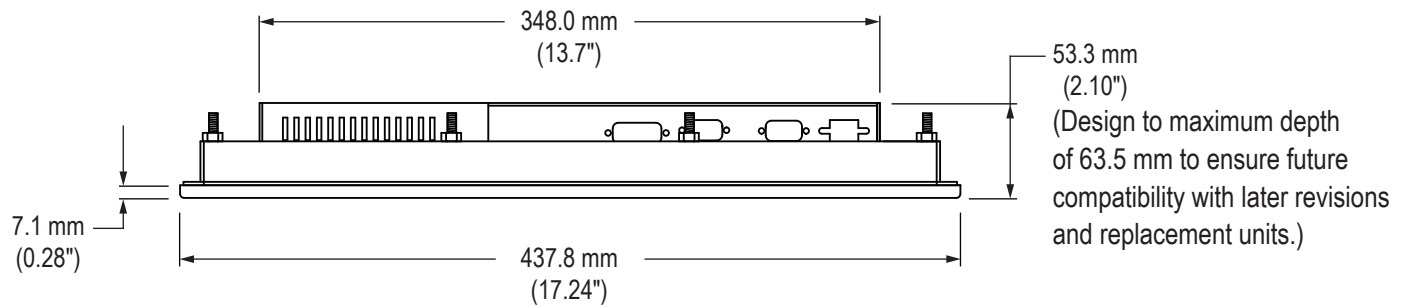

# Cable Connections

## Rear View

100 mm VESA  
MOUNTING PATTERN  
(M4 SCREWS PROVIDED,  
16 mm MAXIMUM DEPTH  
OF SCREW)

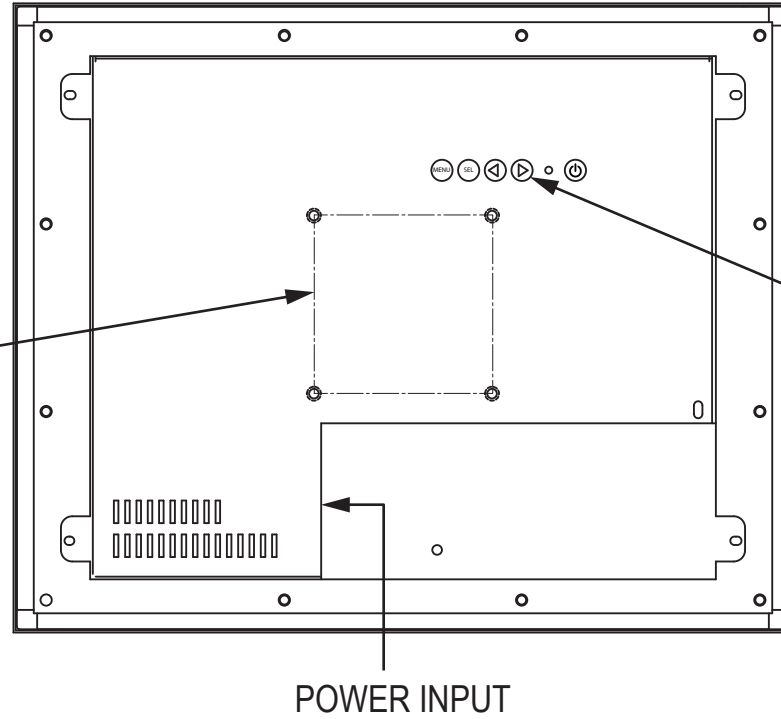

CONTROL PANEL  
BUTTONS

POWER INPUT

## Bottom View

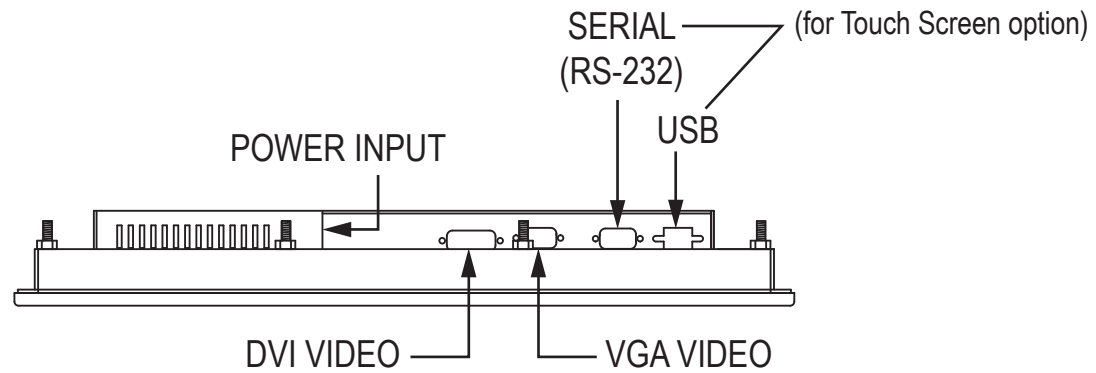

SERIAL (RS-232) (for Touch Screen option)

POWER INPUT

USB

DVI VIDEO

VGA VIDEO

# VB-1517-01 Accessory Mounting Bracket

Rear View

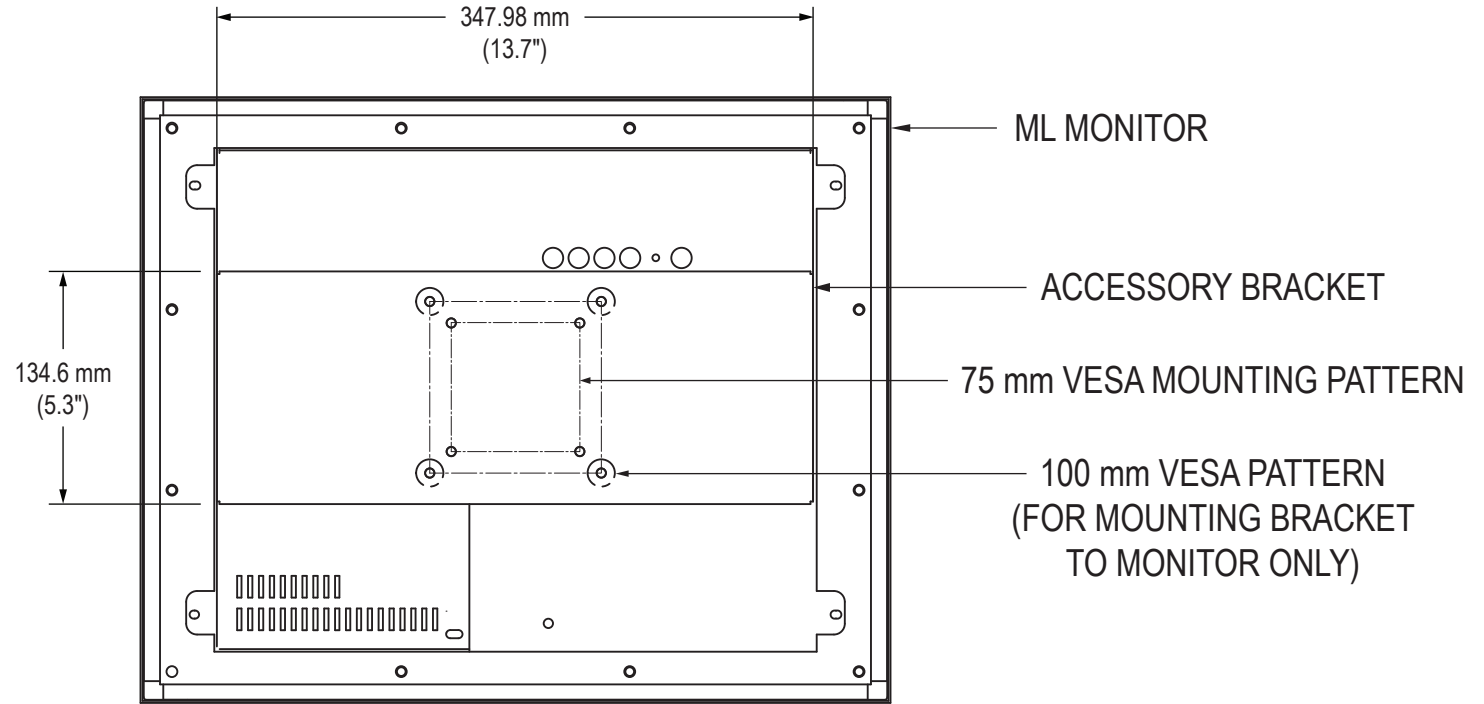

Bottom View

