



Installation Instructions

KVM2EXT-BLK-N4-PS2 or KVM2EXT-SS-N4X-PS2

Rear-Mounted PS2/Serial KVM Extender

▶ IMPORTANT!

TO IDENTIFY COMPUTER RELATED ISSUES AND PREVENT COSTLY TROUBLESHOOTING, BENCH TEST YOUR MONITOR, KVM EXTENDER, KEYBOARD, AND/OR MOUSE WITH YOUR COMPUTER WITH THE PROVIDED 25' CAT5 CABLE.

KVM LOCAL AND REMOTE MODULES COME FROM THE FACTORY AS MATCHED PAIRS (MATCHED BY SERIAL NUMBER) AND ARE TUNED AND TESTED AS SUCH. NEVER USE MISMATCHED PAIRS OF LOCAL AND REMOTE MODULES.



ANY STEPS MARKED WITH THIS SYMBOL ARE REQUIRED TO ENSURE COMPLIANCE WITH CLASS I, II, III, DIVISION 2 HAZARDOUS LOCATION REQUIREMENTS.

1. Install the KVM Local Module and cabling according to the instructions in the Adderlink X2 Dual Access manual.

NOTE: Power supply will be required if PS2 cables are not hooked up to the computer. If your computer does not have PS2 ports, do not use a 3rd party USB to PS2 adapter. Please use the Hope Industrial adapter (part number CUSB-CCP2U).

2. Lay the monitor face down on a clean work surface with the bottom of the monitor facing you. Use a soft cloth or piece of foam as a pad to prevent scratching the front of the monitor.
3. Remove the eight existing screws around the cable access opening on the rear cover of the monitor.

4.  Install the video cable from the KVM Remote Module into the monitor and secure the screw locks. Loosen the retaining clip for the power cable in the monitor's cable well and connect the power cable from the KVM Remote Module to the monitor. Retighten the retaining clip as shown in Figure 1.

5. Refer to Figure 2. Insert the KVM Remote Module into the opening of the rear panel by sliding the right hand locking tabs in all the way to the right. Then, press down firmly and slide the KVM Remote Module to the left until it stops with both left hand locking tabs securely inside the rear panel.

6.  Loosen the power cable retaining clip in the well on the KVM Remote Module. Connect a power cable to the module's power connector then retighten the retaining clip as shown in Figure 3.

7. Install the CAT5 cable from the KVM Local Module into the KVM Remote Module. Many issues with KVM Extender performance can be linked to partial or failing RJ45 crimps. We recommend using high quality crimpers and RJ45 connectors such as:

- LCom PN TDS8PC6 Connectors (for Shielded, Solid or Stranded, CAT6 cables)
- LCom PN TDS8PC5 Connectors (for Shielded, Solid or Stranded, CAT5E cables)
- LCom PN HTS2500 or Hanlong PN HT-236Q Modular Crimper

NOTE: Do not use your KVM Extender to link between different buildings. Linking between different buildings that do not share a common earth ground is not supported and may damage your KVM Extender.

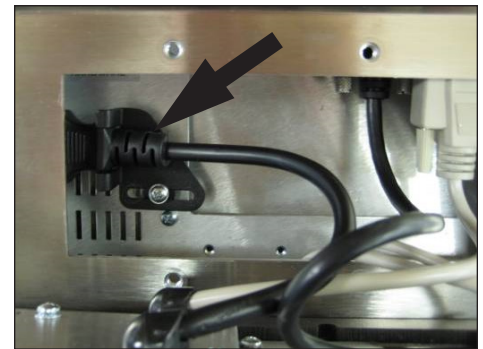

FIGURE 1

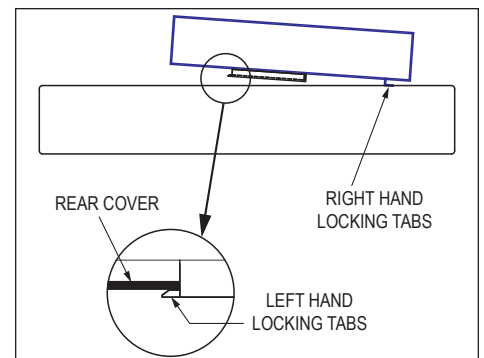

FIGURE 2

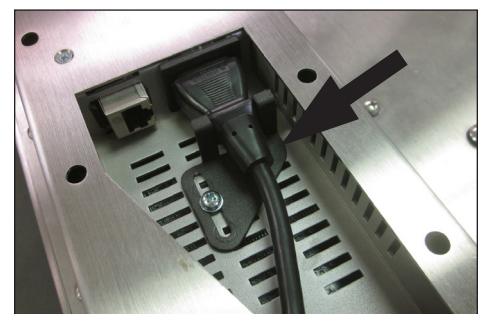

FIGURE 3



Rear-Mounted PS2/Serial KVM Extender Instructions (continued)

8. For monitors without a keyboard, temporarily plug a keyboard into the keyboard PS2 port of the KVM Remote Module. Download the Adder test pattern generator from the following address:

<http://www.HopeIndustrial.com/links/addertest>

Perform the image adjustments found in the "Image controls" and "Skew adjustment" sections of the AdderLink X2 Dual Access manual. After completing the image adjustment, unplug the temporary keyboard and continue to step 10.

9. For monitors with a keyboard, install the keyboard by following the installation instructions that were shipped with the keyboard. Download the Adder test pattern generator from the following address:

<http://www.HopeIndustrial.com/links/addertest>

Plug the connectors into the KVM Remote Module. Perform the image controls and skew adjustment found in the "Image controls" and "Skew adjustment" sections of the AdderLink X2 manual.

10.  For monitors with a keyboard going into hazardous locations:

- Connect PS2 keyboard cables to KVM Extender as shown in Figure 4.
- Install retention bracket by first hooking bracket around post as shown in Figure 4.
- Rotate retention bracket as shown in Figure 5.
- Snap retention bracket into first groove of each PS2 cable strain relief as shown in Figure 6.

NOTE: You will have to support the connectors from underneath.

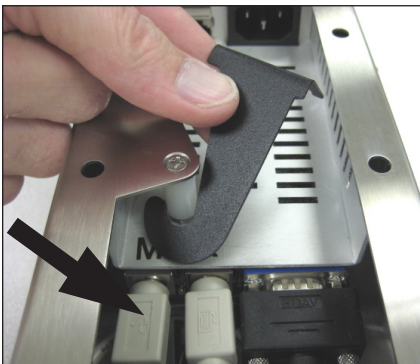

FIGURE 4

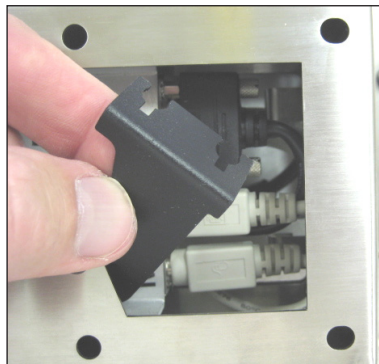

FIGURE 5

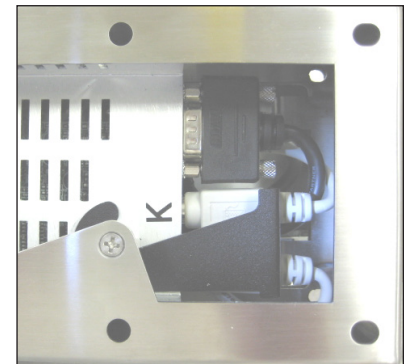

FIGURE 6

11. Install the cover plate using the provided eight sealing screws. Fully tighten all eight screws, then back off one full turn.

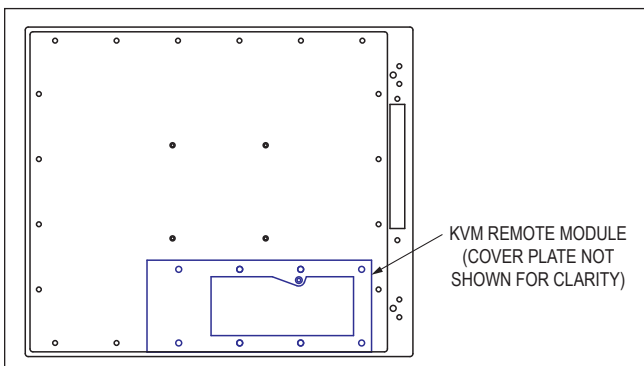

FIGURE 7

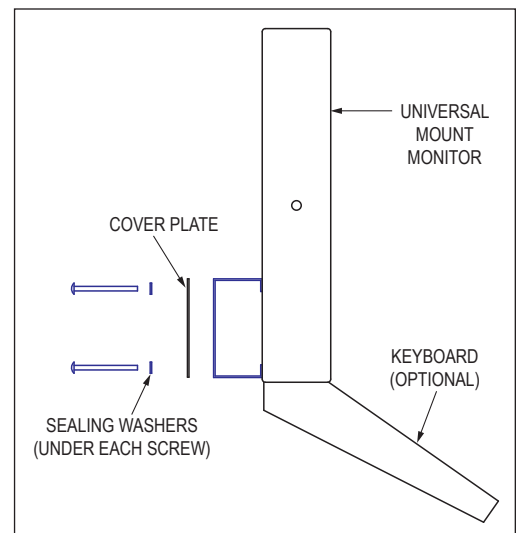

FIGURE 8